



SERVICE BULLETIN #122

04/14/14

8522 Spoke Wheel

Upon depletion of inventory, the 8522 spoke will become obsolete with no direct replacement. We do however recommend a replacement: the 10-stud 1221 hub. This requires changing brake drums, changing to a disc hub, and changing to disc wheels instead of demountable rims. If you have any questions, please contact the Webb Engineering department via email to engineering@webbwheel.com or call 256-736-6356.

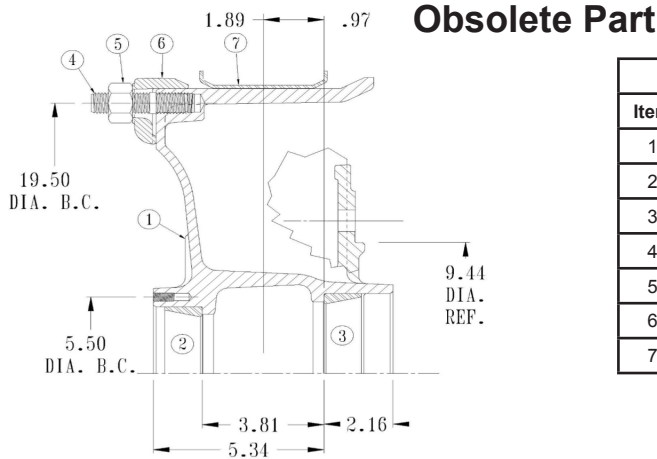

Obsolete Part

8522 Bill of Material			
Item	Part No.	Description	Qty
1	8522F	5 Spoke 22" Wheel	1
2	HM212011	Outer Bearing Cup	1
3	653	Inner Bearing Cup	1
4	171027	Rim Stud	5
5	74710	Hex Nut	5
6	16123	Rim Clamp	5
7	42240	Rim Spacer	1

Replacement Option

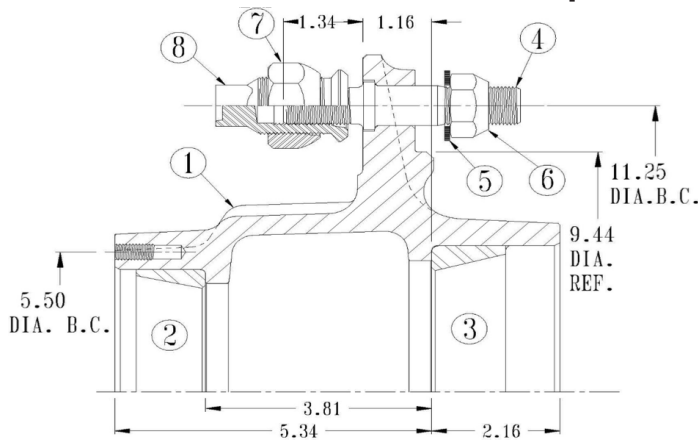

1221 Bill of Material			
Item	Part No.	Description	Qty
1	1221F	10 Stud 11.25" Inboard Trailer Hub	1
2	HM212011	Outer Bearing Cup	1
3	653	Inner Bearing Cup	1
4A	139913	Shoulder Stud 3/4-16 L.H.	10
4B	139902	Shoulder Stud 3/4-16 R.H.	10
5	257	Flat Washer	10
6	75716	3/4-16 Locknut	10
7a	178921	L.H. Outer Capnut	10
7b	178910	R.H. Outer Capnut	10
8a	107083	L.H. Inner Capnut	10
8b	107082	R.H. Inner Capnut	10

REPLACEMENT ASSEMBLIES		
Hub Service Assembly	Wheel Type	ABS
12213--ML	BSN Steel or Aluminum	Non-ABS
12213--MR		Non-ABS

Replacement Drum Numbers	Size
64467B	16.50" x 5.00"
62200B	16.50" x 7.00"
68891B	16.50" x 8.62"
67205B	16.50" x 10.00"